

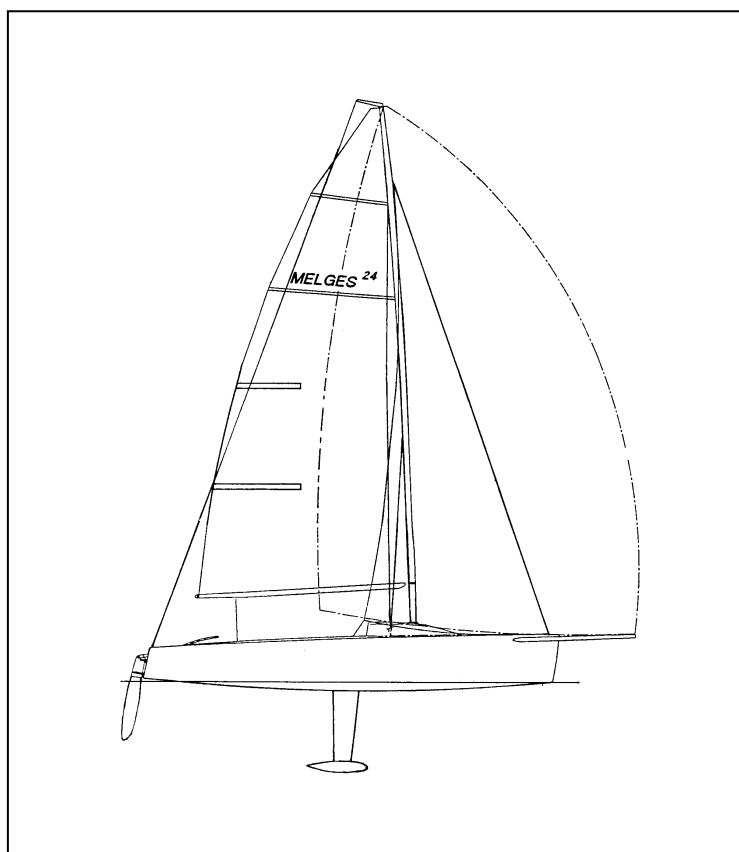

# INTERNATIONAL MELGES 24 CLASS RULES 2013



The Melges 24 was designed in 1992 by Reichel and Pugh and was adopted as an International class in 1997.

# INDEX

---

## PART I – ADMINISTRATION

### Section A – General

A.1	Language .....	4
A.2	Abbreviations .....	4
A.3	Authorities.....	4
A.4	Administration of the Class .....	4
A.5	ISAF Rules .....	4
A.6	Class Rules Variations .....	5
A.7	Class Rules Amendments .....	5
A.8	Class Rules Interpretation .....	5
A.9	International Class Fee and ISAF Building Plaque .....	5
A.10	Sail Numbers .....	5
A.11	Hull Certification .....	5
A.12	Initial Hull Certification .....	5
A.13	Validity of Certificate .....	6
A.14	Hull Re-Certification .....	6
A.15	Retention of Certification Documentation .....	6

### Section B – Boat Eligibility

B.1	Class Rules and Certification ....	6
B.3	Class Association Membership .	6

## PART II – REQUIREMENTS AND LIMITATIONS

### Section C – Conditions for Racing

C.1	General .....	7
C.2	Crew .....	7
C.3	Personal Equipment .....	8
C.4	Advertising .....	8
C.5	Portable Equipment .....	8
C.6	Boat .....	9
C.7	Hull .....	9
C.8	Hull Appendages.....	11
C.9	Rig .....	12

C.10	Sails .....	14
C.11	Boat Handling Rules.....	15

### Section D– Hull

D.1	Parts .....	16
D.2	General .....	16
D.3	Hull Shell .....	17
D.4	Deck .....	17
D.5	Bulkheads & Internal .....	17
D.6	Assembled Hull .....	18

### Section E – Hull Appendages

E.1	Parts .....	18
E.2	General .....	18
E.3	Keel .....	19
E.4	Rudder Blade, Rudder Stock and Tiller .....	19

### Section F – Rig

F.1	Parts .....	20
F.2	General .....	20
F.3	Mast .....	21
F.4	Boom .....	23
F.5	Bowsprit .....	23
F.6	Standing Rigging .....	23
F.7	Running Rigging .....	24

### Section G – Sails

G.1	Parts .....	24
G.2	General .....	24
G.3	Mainsail .....	25
G.4	Headsail .....	26
G.5	Spinnaker .....	28

## PART III – APPENDICES

H.1	Measurement diagrams .....	29
H.2	Fittings .....	31

# INTRODUCTION

---

*The intention of these International Melges 24 Class rules is to ensure the boats are as identical as possible in construction, hull shape, weight, weight distribution, equipment, rigging and sail plan. Therefore, coring, drilling out, rebuilding, replacement of material, grinding or relocating standard equipment, fairing interior or exterior parts of **hull, hull appendages** or **rig** that improves moments of inertia, or changes the standard shapes or contours shall be prohibited.*

*International Melges 24 hulls, hull appendages, rigs and sails are measurement and manufacturing controlled.*

*International Melges 24 hulls shall only be manufactured by Melges Performance Sailboats in the US, Devoti Sailing S.R.O in Europe and Northshore Yachting Services Pty Ltd in Australia – in the class rules referred to as licensed builders.*

*International Melges 24, hull appendages shall only be manufactured by Devoti Sailing S.R.O – in the class rules referred to as the licensed builder.*

*International Melges 24, rigs shall only be manufactured by Southern Spars – in the class rules referred to as the licensed builder.*

*International Melges 24 Sails may be manufactured by optional sailmakers.*

*Equipment is required to comply with the International Melges 24 Building Specifications and is subject to an ISAF approved manufacturing control system.*

*International Melges 24 hulls, hull appendages, rigs and sails may, after having left the manufacturer, only be altered to the extent permitted in Section C of the class rules.*

*Owners and crews should be aware that compliance with rules in Section C is NOT checked as part of the certification process.*

*Rules regulating the use of equipment during a race are contained in Section C of these class rules, in ERS Part I and in the Racing Rules of Sailing.*

*This introduction only provides an informal background and the International Melges 24 Class Rules proper begin on the next page.*

*The class permits IHC for Section D hulls, Section E hull appendages, Section F masts and for Section G sails. Although the licensed builders may operate IHC for sections D, E and F they are also checked by random independent inspection by official measurers.*

*When equipment and/or components are not allowed because they are not specifically permitted by the class rules, then this restriction pertains not only to the use but also the presence of this equipment/component on board.*

**PLEASE REMEMBER:**  
**IF THESE RULES DO NOT SAY YOU CAN,**  
**THEN YOU CANNOT!**

# PART I – ADMINISTRATION

---

## Section A – General

### A.1 LANGUAGE

- A.1.1 The official language of the class is English and in case of dispute over translation the English text shall prevail.
- A.1.2 The word “shall” is mandatory and the word “may” is permissive.

### A.2 ABBREVIATIONS

- A.2.1 ISAF International Sailing Federation
- MNA ISAF Member National Authority
- ICA International Melges 24 Class Association
- NCA National Class Association
- ERS Equipment Rules of Sailing
- RRS Racing Rules of Sailing

### A.3 AUTHORITIES

- A.3.1 The international authority of the class is the ISAF which shall co-operate with the ICA in all matters concerning these **class rules**.
- A.3.2 Notwithstanding anything contained herein, the **certification authority** has the authority to withdraw a **certificate** and shall do so on the request of the ISAF.
- A.3.3 The copyright holder shall be Reichel & Pugh Yacht Design Inc.

### A.4 ADMINISTRATION OF THE CLASS

- A.4.1 ISAF has delegated its administrative functions of the class to MNAs. The MNA may delegate part or all of its functions, as stated in these **class rules**, to an NCA.
- A.4.2 In countries where there is no MNA, or the MNA does not wish to administrate the class, its administrative functions as stated in these **class rules** shall be carried out by the ICA which may delegate the administration to an NCA.
- A.4.3 Neither the ISAF, an MNA, the ICA, an NCA, the copyright holder or an official measurer is under any legal responsibility in respect of these class rules.
- A.4.4 A measurer shall seek approval from the ICA, but shall only be an official measurer when recognised or appointed by a MNA.

### A.5 ISAF RULES

- A.5.1 These **class rules** shall be read in conjunction with the ERS.
- A.5.2 Except where used in headings, when a term is printed in “**bold**” the definition in the ERS applies and when a term is printed in “*italics*” the definition in the RRS applies.

## **A.6 CLASS RULES VARIATIONS**

A.6.1 At Class Events – see RRS 89.1.d) – ISAF Regulation 10.5(f) applies. At all other events RRS 87 applies.

## **A.7 CLASS RULES AMENDMENTS**

A.7.1 Amendments to these **class rules** are subject to the approval of the ISAF in accordance with the ISAF Regulations.

## **A.8 CLASS RULES INTERPRETATION**

A.8.1 Interpretation of **class rules** shall be made in accordance with the ISAF Regulations.

## **A.9 INTERNATIONAL CLASS FEE AND ISAF BUILDING PLAQUE**

A.9.1 The licensed hull builder shall pay the International Class Fee.

A.9.2 The Copyright Holder shall, after having received the International Class Fee for the hull, send the ISAF Building Plaque and a measurement form to the licensed hull builder. ISAF plaques were issued from sail number 350 onwards.

## **A.10 SAIL NUMBERS**

A.10.1 Sail numbers shall correspond to the number on the International Class Building Fee Plaque. Boats with sail numbers prior to 350 shall carry the number as issued by Melges Performance Boatworks.

## **A.11 HULL CERTIFICATION**

A.11.1 A **certificate** issued after March 2009 shall record the following information:

- (a) Class
- (b) **Certification authority**
- (c) Sail number
- (d) Owner
- (e) Hull identification
- (f) Builder/Manufacturers details
- (g) Date of issue of initial **certificate**
- (h) Date of issue of **certificate**
- (i) Keel weight
- (j) Keel serial number
- (k) Complete boat weight
- (l) Corrector weights

## **A.12 INITIAL HULL CERTIFICATION**

A.12.1 For a **certificate** to be issued to hull not previously **certified**:

- (a) **Certification control** shall be carried out by the **official measurer** who shall complete the appropriate documentation.
- (b) The documentation and **certification** fee, if required, shall be sent to the **certification authority**.

- (c) Upon receipt of a satisfactorily completed documentation and **certification** fee, if required, the **certification authority** may issue a **certificate**.

### **A.13 VALIDITY OF CERTIFICATE**

A.13.1 A hull **certificate** becomes invalid upon:

- (a) the change to any items recorded on the hull **certificate** as required under A.11.
- (b) withdrawal by the **certification authority**,
- (c) the issue of a new **certificate**,

### **A.14 HULL RE-CERTIFICATION**

A.14.1 The **certification authority** may issue a **certificate** to a previously certified hull:

- (a) when it is invalidated under A.13.1(a) and/or after receipt of the old **certificate**, and **certification** fee if required.
- (b) when it is invalidated under A.13.1 (b), at its discretion.
- (c) in other cases, by application of the procedure in A.12.

### **A.15 RETENTION OF CERTIFICATION DOCUMENTATION**

A.15.1 The **certification authority** shall:

- (a) retain the original documentation upon which the current **certificate** is based.
- (b) upon request, transfer this documentation to the new **certification authority** if the hull is exported.

## **Section B – Boat Eligibility**

For a **boat** to be eligible for *racing*, it shall comply with the rules in this section.

### **B.1 CLASS RULES AND CERTIFICATION**

B.1.1 The boat shall:

- (a) be in compliance with the **class rules**.
- (b) have a valid hull **certificate**.
- (c) have valid **certification marks** as required. The International Class building fee plaque shall be permanently displayed on the starboard side, aft face of the transom.

### **B.2 CLASS ASSOCIATION MEMBERSHIP**

B.2.1 The owner and helmsman shall be a current member of their NCA or, where there is no NCA in his country, a member of the ICA or and NCA nominated by the ICA

B.2.2 Sails shall carry a Class Association Sail Label.

# PART II – REQUIREMENTS AND LIMITATIONS

---

The **crew** and the **boat** shall comply with the rules in Part II when *racing*. In case of conflict Section C shall prevail.

The rules in Part II are **closed class rules**. **Certification control** and **equipment inspection** shall be carried out in accordance with the ERS except where varied in this Part.

## Section C – Conditions for Racing

### C.1 GENERAL

#### C.1.1 RULES

- (a) RRS 49.2 is changed in that the lines are hiking lines and tension may be modified.  
RRS 42.3(c) is modified to allow the spinnaker sheet to be played without restriction.
- (b) The ERS Part I – Use of Equipment shall apply.

### C.2 CREW

#### C.2.1 LIMITATIONS

- (a) The **crew** shall consist of a minimum of 3 persons.
- (b) No **crew** member shall be substituted during an event of less than 7 consecutive days, unless prior written permission has been granted by the race committee or Jury.
- (c) RRS 43.2 applies with regard to clothing weight although the line tension may be modified.
- (d) The number of **crew** shall not change during a regatta unless written permission has been granted by the Race Committee.

#### C.2.2 WEIGHTS

	minimum	Maximum
The total weight of the <b>crew</b> dressed in underwear	kg	375 kg

At official International Melges 24 Class events as decreed by the International Melges 24 Class Association this rule shall be administered as per H.3

### **C.3 PERSONAL EQUIPMENT**

#### **C.3.1 MANDATORY**

- (a) The boat shall be equipped with **personal buoyancy** for each crew member to the minimum standard ISO12402:5 (CE 50 Newtons), or USCG Type III, or AUS PFD 1.

### **C.4 ADVERTISING**

#### **C.4.1 LIMITATIONS**

Advertising shall only be displayed in accordance the ISAF Advertising Code. (See ISAF Regulation 20). Subject to the limitations of Regulation 20, advertising chosen by the person in charge may be displayed.

### **C.5 PORTABLE EQUIPMENT**

#### **C.5.1 FOR USE**

(a) **MANDATORY**

- (1) One manual bilge pump
- (2) One bucket of not less than 9ltr capacity, with a lanyard of minimum 1 metre.
- (3) One anchor and chain combined of not less than 5 kg in weight and with the anchor of not less than 3.1kg
- (4) One anchor line of not less than 40 m of line of not less than 8 mm in diameter
- (5) Two main companionway hatches
- (6) The engine tray carried under the engine.

(b) **OPTIONAL**

- (1) Electronic or mechanical timing devices
- (2) Navigation lights, tactical and navigational instruments and their associated power sources.
- (3) Mooring lines
- (4) Cool/ice box
- (5) Bunk cushions and portable toilet. Cushions shall be on the bunks and the toilet stowed under the companionway step.
- (6) Protective bag for companionway hatches
- (7) The 6 hatches from the cabin 'V' berth/settees

#### **C.5.2 NOT FOR USE**

(a) **MANDATORY**

- (1) One functioning outboard engine and bracket:
  - 2 stroke minimum nominal power – 2kw (3hp)
  - 4 stroke minimum nominal power - 1.46kw (2hp)
  - Electric outboard of minimum power 450kw
  - Minimum engine weight empty of fuel – 12.5kg



- (2) When not in use, engine and outboard bracket shall be stowed in the engine berth below the main cockpit.
- (3) The boat shall depart the dockside with the engine tank full and suitable separate container with a minimum 3lts of fuel or in the case of an electric outboard the battery power pack fully charged.

## C.6 BOAT

### C.6.1 WEIGHT

	minimum	Maximum
The weight of the <b>boat</b> in dry condition	809 kg	kg

The weight shall be taken excluding **sails** - engine, bracket and fuel can – anchor chain and warp – manual bilge pump – bucket and lanyard - and all portable equipment as listed in C.5.1(b) except that the permanently fixed parts of timing and navigational/tactical equipment (e.g. display heads and sensors) may be included in the weight. All batteries and power sources shall be removed with the exception of fixed solar panels powering instruments.

### C.6.2 CORRECTOR WEIGHTS

- (a) **Corrector weights** of lead shall be equally divided fore and aft and permanently fastened in the locations on the diagram in section H when the **boat** weight is less than the minimum requirement.
- (b) The total weight of such **corrector weights** shall not exceed 20 kg. See also rules A.13 and B.1.1.
- (c) The aft corrector weight on the fore side of the bulkhead may be split equally part and starboard.
- (d) Corrector weights shall not be reduced more than once every 12 months.

### C.6.3 MAINTENANCE

- (a) The use of a snorkel and of a mask, of brand and dimensions available on the market, is allowed.

## C.7 HULL

### C.7.1 MODIFICATIONS, MAINTENANCE AND REPAIR

- (a) The moulded gel coat below the waterline and for not more than 30mm above the waterline may be lightly abraded back to allow for the application and adhesion of anti-fouling products, for those boats to be left afloat. The abrasion of the gel coat shall be the minimum needed to ensure adhesion of the coating and shall not involve fairing of any sort. The application of paint and epoxy treatments, whilst allowed, shall be completed under the supervision of a measurer.
- (b) Normal propriety polishes may be used on the hull if in compliance with RRS 53.
- (c) Sanding is prohibited on all hull, deck and internal structures unless repair of superficial damage is required. If there is any doubt to the interpretation of “superficial damage”, a ruling shall be sought from a measurer or the

technical committee before repair work commences and the boat offered for re-measurement on completion.

- (d) If the hull requires to be painted to repair a damaged gelcoat, the process shall be reported to a measurer and the boat offered for **re-certification** on completion
- (e) Fairing the keel box area or keel box Delrins is prohibited. The Delrin may be bedded in on optional material and adjusted to fit flush with the underside of the hull.
- (f) A metal plate may be used to reinforce the transom behind the fittings for boats needing repair in this area. The plate shall not exceed 4mm in thickness.

#### C.7.2 FITTINGS

##### (a) USE

- (1) The rear gate line across the transom shall be closed whilst racing. It shall be in one continuous piece, fixed using either a shackle, carabineer or lashing of optional design. The deflection at the centre when measured from a straight line between the attachment points shall not be more than 100mm.
- (2) The hiking line shall be attached at the deck fitting forward and to the designed eye on the pulpit aft. The method of attachment is optional.
- (3) Padding may be fitted to the hiking lines. The line may be either a continuous line with added padding or lines (with or without padding) linked by webbing sections. The method of joining the hiking line and the webbing is optional. The webbing shall be a minimum of 50mm wide.
- (4) From the aft stanchion, the hiking line may be led down and through either a block or a shackle attached to the spinnaker turning block deck eye, or through the deck eye itself, and up to the stern pulpit.
- (5) When pushing down hard on the hiking lines at the mid point between the two centre stanchions, no part of the hiking line including padding etc shall touch the deck.
- (6) Additional foot chocks may be fitted to the cockpit floor, including moulded foot chocks and on the engine hatch cover. The shape is optional. They shall not exceed 100mm in height above the horizontal surface of the cockpit floor.
- (7) A proprietary hatch not exceeding 220mm in internal diameter may be fitted to the cockpit floor to allow access to the rudder and backstay fittings
- (8) Fairings of any material may be used over blocks on deck to assist in the free running of sheets and control lines. To protect the spinnaker, a deflector or similar device of optional design may be installed totally within a 300mm radius of the forward most point of the hiking lines.
- (9) Storage bags may be attached to the cockpit moulding.

- (10) Protective covers may cover the shrouds, vang and recess for the furler drum.
- (11) Non slip tape or similar non slip material may be added to the decks, cockpit floor and gunwale edge as necessary.

## C.8 HULL APPENDAGES

### C.8.1 MODIFICATIONS, MAINTENANCE AND REPAIR

- (a) Normal propriety polishes may be used on the **hull appendages** if in compliance with RRS 53.

### C.8.2 KEEL

- (a) DIMENSIONS with keel fully lowered:

	minimum	maximum
<b>Hull datum point</b> to intersection of hull and fin trailing edge, around hull on centreline	3482 mm	3494 mm
<b>Hull datum point</b> to intersection of fin trailing edge and top of keel bulb, straight line	3784 mm	3823 mm
Underside of hull in a straight line to top of keel bulb at the trailing edge of the keel	1195 mm	1215 mm

- (b) USE

- (1) The **keel** shall be fixed down using the supplied locking strap.
- (2) The **keel** shall only be retracted when not racing, using the Melges designed lifting crane

### C.8.3 RUDDER

- (a) DIMENSIONS

	minimum	maximum
<b>Hull datum point</b> to trailing edge of rudder tip	mm	1220 mm

- (b) USE

- (1) The rudder head between gudgeons shall be parallel to the transom, +/- 2mm.
- (2) Shims may be fitted between the rudder and tiller to ensure a good fit.

## C.9 RIG

### C.9.1 MODIFICATIONS, MAINTENANCE AND REPAIR

- (a) Routine maintenance such as cleaning, polishing, repair of minor abrasions and the replacement of fittings is permitted without re-measurement and re-**certification**

### C.9.2 LIMITATIONS

- (a) Only one set of **spars** and standing **rigging** shall be used during an event of less than 7 consecutive days, except when an item has been lost or damaged beyond repair.

### C.9.3 MAST

#### (a) USE

- (1) The mast may be fitted with a protective gaiter below the gooseneck.
- (2) The spreader connector bar shall not be modified or changed during a regatta.
- (3) The mast as supplied and assembled in accordance with the building specification shall be stepped on the standard mast step. No wedges or similar devices shall be used to control or alter the rake or bend characteristics of the rig, except that permanently attached shims may be used to correct misalignment.
- (4) The **mast** shall be fitted with a securely fixed sail track stop as supplied by the licensed builders.

### C.9.4 BOOM

#### (a) DIMENSIONS

	minimum	maximum
<b>Limit mark width</b>	15 mm	-
<b>Boom point distance</b>		3800 mm

#### (b) USE

- (1) The intersection of the aft edge of the mast **spar** and the top of the boom **spar**, each extended as necessary, shall not be below the upper edge of the mast **lower limit mark** when the boom **spar** is at 90° to the mast **spar**.
- (2) A shackle, block or similar device may be fitted to the underside of the boom to help guide the spinnaker halyard.
- (3) The **boom** shall be fitted with a securely fixed sail track stop as supplied by the licensed builders.
- (4) The boom may be fitted with a security line including fittings.

### C.9.5 RETRACTING BOWSPRIT

#### (a) USE

- (1) A batten or similar may be fitted to the end of the bowsprit. It shall extend not more than 300mm from the outer end.
- (2) The retraction line is optional. The bowsprit may be retracted by a knot in the tack line.
- (3) The bowsprit shall be capable of being retracted to have its forward end level with or aft of the forward side of the stem.
- (4) Tape or other materials may be added around the bowsprit to help ensure a watertight seal.

#### (b) DIMENSIONS

	minimum	maximum
Centre of “u” bolt to foreside of stem – straight line	1400 mm	mm

## C.9.6 STANDING RIGGING

### (a) USE

- (1) The shrouds and forestay may be attached and adjusted by turnbuckles/bottlescrews of optional design. Lock plates may be fitted.
- (2) Rigging links and rigging screws may be adjusted while racing, but at the shroud plate only. Remote adjustment of any type is prohibited.

## C.9.7 RUNNING RIGGING

### (a) USE

- (1) The main halyard shall be secured below deck. It shall use a sheet stopper and/or cleats mounted on the starboard side of the compression tube. It may be tensioned by a purchase of not more than 4:1 (including a cleat if required) and one hook or fastening. It shall not lead to the deck nor be able to be operated from above deck.
- (2) The jib shall be hoisted by one of 3 options:
  - (a) The s/s wire jib halyard connected to the jib luff wire, through the original jib sheave and which shall be secured to the high field lever.

OR

(b) An HMPE or similar (e.g. Spectra) halyard, running inside the zip luff. The design of the system is optional.

OR (c) An HMPE or similar halyard led through the original jib sheave in the mast and secured to a purchase system below deck. The design of the system is optional but the purchase system shall be entirely below deck.

The choice of system is optional except that it shall not be changed during a regatta.

An existing mast may be retro fitted with the fixed forestay using the official parts available from the licensed builders.

- (3) The complete boom vang as supplied may be fitted with the cleat at either mast or boom end.
- (4) The spinnaker sheet may have a single gybe line spliced into them at the clew.
- (5) The use of shock cord is unrestricted except that it may not be used on the rear gate line or to retract the bowsprit in any way.
- (6) No lines shall lead below deck other than the main halyard, jib halyard, jib furling line and the bow sprit launch and recovery line with tackle.
- (7) The Cunningham may be led through the mainsail eye/block and tied off on the gooseneck fitting or may be led through the mainsail eye/block and through a block attached to the gooseneck fitting and tied off to the tack lower eye/cringle, but not tied off to the higher eye/block.

## C.10 SAILS

### C.10.1 MODIFICATIONS, MAINTENANCE AND REPAIR

- (a) **Sails** shall not be altered in any way except as permitted by these **class rules**.
- (b) Routine maintenance such as cleaning and minor repairs is permitted without re-measurement and re-**certification**.

### C.10.2 LIMITATIONS

- (a) Not more than 1 mainsail, 1 headsail and 2 spinnakers shall be carried aboard.
- (b) Not more than 1 mainsail, 1 headsail and 2 spinnakers shall be presented for registration and used during an event of less than 8 consecutive days, except when a **sail** has been lost or damaged beyond repair.
- (c) Sails shall not be changed or substituted whilst underway or away from the dockside.

### C.10.3 MAINSAIL

#### (b) USE

- (1) The **sail** shall be hoisted on a halyard. The arrangement shall permit hoisting and lowering of the **sail** at sea.
- (2) The highest visible point of the **sail**, projected at 90° to the mast **spar**, shall not be set above the lower edge of the mast **upper limit mark**. The intersection of the **leech** and the top of the boom **spar**, each extended as necessary, shall not be behind the fore side of the boom **outer limit mark**.
- (3) The **Luff** bolt rope shall be in the **spar** grooves.
- (4) The mainsail shall be attached to the boom only at the **clew**

### C.10.4 JIB

#### (a) USE

- (1) The jib shall be capable of being furled around the forestay, from the cockpit, using the designed furling system.

### C.10.5 SPINNAKER

#### (a) IDENTIFICATION

The sail numbers and national letters are optional. This changes RRS G1.3

(d).

#### (b) USE

- (1) The spinnaker may be stowed in a bag in the companionway hatch. The design of this bag is optional.

## C.11 BOAT HANDLING RULES

- C.11.1. Approaching a windward mark without the spinnaker set, the bowsprit shall not be extended until the bow of the boat has passed the mark. If for a wind shift, or any other reason, the spinnaker is flown on a 'windward' leg, then the bowsprit shall be fully extended and the spinnaker set before the boat reaches the zone at a mark.

- C.11.2. When the bowsprit is extended the boat shall be in the process of a continuous hoist, or flying or dropping the spinnaker.
- C.11.3. The skipper or crew shall not hike out by sitting facing outboard over the spinnaker turning block. The skipper/helmsman shall not sit in any way that projects the body below the waist beyond the sheerline, nor shall they use any fitting or device with which to hike from any part of the body below the waist.
- C.11.4. When tacking, or gybing, standing up and hanging or pushing/leaning on the shrouds, mast or any other item to promote the manoeuvre shall be prohibited.
- C.11.5. RRS 42.3 (c) is modified to allow the spinnaker sheet to be trimmed without restrictions in all conditions
- C.11.6. When hiking, the crews shall either sit facing outboard in such a way that at least a part of the back of the thigh/buttocks is in contact with the deck or gunwale edge, kneel on the aft corner of the side deck or, stand with at least one foot on the cockpit floor.
- C.11.7. While sailing with the spinnaker, crew may only stand forward of the mast when tacking or gybing, or in order to perform repairs.

## Section D – Hull

### D.1 PARTS

#### D.1.1 MANDATORY

- (a) Hull shell
- (b) Deck
- (c) Internal mouldings and bulkheads
- (d) Engine stowage tray
- (e) Mast compression post

### D.2 GENERAL

#### D.2.1 RULES

- (a) The **hull** shall comply with the **class rules** in force at the time of initial **certification**.

#### D.2.2 CERTIFICATION

See Rule A.12. The **official measurer**, the ICA, the MNA or the ISAF may use destructive testing to determine compliance with construction rules.

#### D.2.3 MODIFICATIONS, MAINTENANCE AND REPAIR

- (a) The hull shell, deck, bulkheads, and cockpit shall not be altered in any way except as permitted by these **class rules**.
- (b) Holes not bigger than necessary for the installation of through core knot meters and depth sounders may be made in the hull shell.
- (c) Routine maintenance such as painting and polishing and minor repairs is permitted without re-measurement and re-**certification**.
- (d) If any hull moulding is substantially altered or repaired in any other way than described in D.2.3(c), its measurement certificate shall cease to be

valid until the relevant parts of the hull have been re-measured and the measurement certificate re-validated by the MNA.

#### D.2.4 DEFINITIONS

##### (a) HULL DATUM POINT

The **hull datum point** is the intersection, on the centreplane of the **hull** between the underside of the shell and the transom upstand, each extended as necessary.

- (b) The fore and aft position of deck fittings shall be measured from the forward side of a straight measurement beam (MB) minimum 2400mm in length, (not less than 100mm wide), laid across the boat on the deck and against the aft face of the cabin. Measurements shall be taken parallel to the fore and aft centreline of the yacht. The beam may have cut outs to fit around any instruments fitted in the aft face of the cabin.

#### D.2.5 IDENTIFICATION

- (a) Hulls from sail number 350 onwards shall carry the ISAF Plaque permanently placed on the starboard side, aft face of the transom.

- (b) All boats shall carry an official serial number which shall include the sail number/ ISAF plaque number, moulded into or securely fixed to the starboard side, aft face of the transom. This number shall be either; part of a national requirement such as European Standard ISO 10087: 1996 for those relevant countries, or, where the builder does not have to conform to a national requirement, or does not intend for his boats to be imported into Europe, the number shall be from a series formulated by Melges Performance Sailboats. The sail number shall be clearly identifiable on the transom.

#### D.2.6 BUILDERS

- (a) The hull shall be built by a builder licensed by Copyright Holder.
- (b) All moulds shall be approved by the Copyright Holder and ISAF.
- (c) The licensed builder shall, at his own expense, correct or replace any hull that does not comply with the class rules as a result of an omission or error by the builder, if the hull is submitted for fundamental measurement within twelve months of purchase.

### D.3 HULL SHELL

#### D.3.1 MATERIALS

- (a) The hull shell shall be built from glass reinforced materials within the builder's license.

#### D.3.2 CONSTRUCTION

- (a) The hull shell shall be built from approved moulds in accordance with the licensed building specifications.



## **D.4 DECK**

### **D.4.1 MATERIALS**

- (a) The deck shall be built from glass reinforced materials within the builder's license.

### **D.4.2 CONSTRUCTION**

- (a) The deck shall be built from approved moulds in accordance with the licensed building specifications.

## **D.5 BULKHEADS AND INTERNAL MOULDINGS**

### **D.5.1 MATERIALS**

- (a) The bulkheads and internal structures shall be built from glass reinforced materials within the builder's license.

### **D.5.2 CONSTRUCTION**

- (a) The bulkheads and internal structures shall be built from approved moulds in accordance with the licensed building specifications.

## **D.6 ASSEMBLED HULL**

### **D.6.1 FITTINGS**

#### **(a) MANDATORY**

Fittings shall be positioned in accordance with the building specification and not modified unless stated within these rules: SEE H.2

#### **(b) OPTIONAL**

- (1) Bow pulpit as per building specification
- (2) One drain plug in the transom.

## **Section E – Hull Appendages**

### **E.1 PARTS**

#### **E.1.1 MANDATORY**

- (a) **Keel**
- (b) **Rudder**

### **E.2 GENERAL**

#### **E.2.1 RULES**

- (a) **Hull appendages** shall comply with the **class rules** in force at the time of **certification**.

#### **E.2.2 MODIFICATIONS, MAINTENANCE AND REPAIR**

- (a) Hull appendages shall not be altered in any way except as permitted by these class rules.
- (b) Routine maintenance such as cleaning, polishing and the repair of superficial damage and abrasions is permitted without re-measurement and re-certification. If there is doubt of the interpretation of "superficial

damage” a ruling shall be sought from an **official measurer** or the technical committee before work commences. On completion the **appendage** shall be **re-certified**.

#### E.2.3 CERTIFICATION

- (a) The **official measurer** shall **certify hull appendages**.
- (b) An MNA may appoint one or more persons at a manufacturer to measure and **certify hull appendages** produced by that manufacturer in accordance with the ISAF In-house Certification Guidelines.
- (c) The official templates shall be those registered with and approved by ISAF.

#### E.2.4 MANUFACTURERS

- (a) The **hull appendages** shall be made by manufacturers licensed by the copyright holder and ISAF.
- (b) The manufacturer shall, at his own expense, correct or replace any **hull appendage** that does not comply with the class rules as a result of an omission or error by the builder, if the **hull appendage** is submitted for fundamental measurement within twelve months of purchase.

### E.3 KEEL

#### E.3.1 RULES

- (a) The keel shall have a unique serial number on the part of the keel which remains inside the boat.
- (b) The keel fin and keel bulb shall at no time be transferred from one hull to another without full **re-certification** to current class rules.

#### E.3.2 MATERIALS

- (a) The **keel** fin shall be of carbon fibre reinforced materials specified in the building specification.
- (b) The **keel** bulb shall be of lead.
- (c) The **keel** bulb shall be covered as per the building specifications.

#### E.3.3 CONSTRUCTION

- (a) The **keel** shall be manufactured from a moulds approved by the Copyright holder and ISAF.

#### E.3.4 FITTINGS

##### (a) MANDATORY

- (1) The forward edge of the keel shall be fitted with a kelp cutter to the Melges design. The slot in which the cutter operates shall not be filled or covered.
- (2) The keel fin shall be fitted with a removable stainless steel ring used to lift the keel with the Melges keel crane.

E.3.5 DIMENSIONS

The keel fin and keel bulb shall conform to official templates.

E.3.6 WEIGHTS

	minimum	maximum
Combined keel fin and keel bulb	300 kg	313 kg

**E.4 RUDDER BLADE, RUDDER STOCK AND TILLER**

E.4.1 RULES

- (a) The **rudder** blade shall have a unique serial number on the side of the **rudder** head.

E.4.2 MATERIALS

- (a) The **rudder** blade shall be of carbon fibre reinforced materials specified in the building specification.
- (c) The tiller shall be of fibre reinforced materials specified in the building specification
- (d) The tiller extension material is optional.

E.4.3 CONSTRUCTION

- (a) The **rudder** blade shall be manufactured in a mould approved by the Copyright holder and ISAF.

E.4.4 FITTINGS

(a) MANDATORY

- (1) The rudder shall be attached to the transom by means of 2 pintles on the rudder and 2 fittings, with loose pin or pins, on the transom. These fittings shall comply with official drawings

(b) OPTIONAL

- (1) Tiller extension

E.4.5 DIMENSIONS

The rudder shall conform to official templates.

	minimum	maximum
Tiller extension perpendicular from tiller surface	mm	1100 mm

E.4.6 WEIGHTS

	minimum	maximum
Rudder including gudgeons and fixing bolts	7.5 kg	mm
Tiller inc extension and bolt to fix tiller to rudder	1.8 kg	

## Section F – Rig

### F.1 PARTS

#### F.1.1 MANDATORY

- (a) **Mast**
- (b) **Boom**
- (c) Standing **rigging**
- (d) Running **rigging**
- (e) **Bowsprit**

### F.2 GENERAL

#### F.2.1 RULES

- (a) The **spars** and their fittings shall comply with the **class rules** in force at the time of **certification** of the **spar**.
- (b) The standing and running **rigging** shall comply with the **class rules**.

#### F.2.2 MODIFICATIONS, MAINTENANCE AND REPAIR

- (a) **Spars** shall not be altered in any way except as permitted by these **class rules**.
- (b) Routine maintenance such as cleaning, polishing, repair of minor abrasions and the replacement of fittings is permitted without re-measurement and re-**certification**.

#### F.2.3 CERTIFICATION

- (a) The **official measurer** shall **certify spars**.
- (b) No **certification** of standing and running **rigging** is required.
- (c) An MNA may appoint one or more persons at a spar maker to measure and **certify spars** produced by that manufacturer in accordance with the ISAF In-house Certification Guidelines.

#### F.2.4 DEFINITIONS

##### (a) MAST DATUM POINT

The **mast datum point** is the top face of the mast foot casting as per the diagram in section H.

#### F.2.5 MANUFACTURER

- (a) The **spar** builder shall be licensed by the Copyright holder.
- (b) The manufacturer shall, at his own expense, correct or replace any spar that does not comply with the class rules as a result of an omission or error by the builder, if the spar is submitted for fundamental measurement within twelve months of purchase.
- (c) The manufacturer of standing and running rigging is optional.

### F.3 MAST

#### F.3.1 MATERIALS

- (a) The **spar** shall be of carbon fibre reinforced materials specified within the builders licence.

#### F.3.2 CONSTRUCTION

- (a) The **spar** shall be built from moulds approved by the Copyright Holder and ISAF and to the approved building specification.
- (b) The **spar** shall be fitted out to the requirements of the building specification.
- (c) From the 1st November 2008, the mast shall be constructed with the fittings needed for the fixed forestay system as per the builder's specification. An existing mast may be retro fitted with the fixed forestay using the official parts available from the licensed builders.

#### F.3.3 FITTINGS

- (a) The following are permitted
- Mast head crane, backstay batten, wind vane, sheaves and sheave boxes, tangs and T ball sockets, one pair of spreaders, spreader attachments, gooseneck, boom vang fitting, halyard cleats and line stowage cleats, supplied mast foot, compass bracket, mast alignment shims, protective cloth sleeves and items as permitted or prescribed by other applicable *rules*.
- (b) Spreader, including the spreader bar, to the approved design shall only be supplied by the licensed builder. The spreaders shall be connected with the spreader bar only.
- (c) The mast head crane shall be fitted with a sail batten connected to the backstay. The length and specification of the batten is optional and it may be fitted with a ring, block or similar.

#### F.3.4 DIMENSIONS

	minimum	maximum
<b>Mast spar cross section</b> above the mast foot		
<b>fore-and-aft</b>	115 mm	122 mm
<b>transverse</b>	74 mm	78 mm
<b>Mast spar cross section at upper point</b>		
<b>fore-and-aft</b>	77 mm	88 mm
<b>transverse</b>	62 mm	70 mm
<b>Mast limit mark width</b>	15 mm	mm
<b>Lower point height</b>	710 mm	mm
<b>Upper point height</b>	-	9528 mm
<b>Forestay height</b>	8300 mm	8330 mm
<b>Main Shroud height</b>	8270 mm	8290 mm
<b>Lower Shroud Height</b>	4160 mm	4180 mm
<b>Spinnaker hoist height</b>	9455 mm	9475 mm
Spinnaker halyard sheave bearing surface	30 mm	40 mm

	minimum	maximum
diameter		
Jib halyard height	8210 mm	8230 mm
Jib halyard sheave bearing surface diameter	48 mm	80 mm
<b>Spreader;</b>		
<b>length</b>	810 mm	830 mm
<b>height</b>	4285 mm	4305 mm
aft side of mast to taut line on aft side of shrouds	230 mm	260 mm
Backstay Crane		
Top aft corner vertically above <b>upper point</b>	-	235 mm
From aft face of mast	-	320 mm
Start of taper above <b>mast datum point</b>	7950 mm	
Constant section to this point		

#### F.3.5 WEIGHTS

	minimum	maximum
<b>Mast weight</b>	28 kg	kg
<b>Mast tip weight</b>	10 kg	

### F.4 BOOM

#### F.4.1 MATERIALS

- (a) The **spar** shall be of aluminium alloy.
- (b) Permitted surface finish shall be anodised.

#### F.4.2 CONSTRUCTION

- (a) The **spar** extrusion shall be approved by ISAF.
- (b) The **spar** shall be built and fitted out to the requirements of the building specification.

#### F.4.3 FITTINGS

- (a) The following are permitted  
Clew outhaul and fittings, sheaves and sheave boxes, blocks, cleats, hooks, attachment fittings, spinnaker stowage fittings, reefing fittings and items as permitted or prescribed by other applicable *rules*.

### F.5 BOWSPRIT

#### F.5.1 MANUFACTURER

- (a) The builders shall be licensed by the Copyright Holder.
- (b) Builders shall only build bowsprits from moulds approved by the Copyright Holder and ISAF.

#### F.5.2 MATERIALS

- (a) The **spar** shall be of carbon fibre.

#### F.5.3 CONSTRUCTION

- (a) The construction shall be as per specified in the builders license.

#### F.5.4 FITTINGS

- (b) (a) The following are permitted: Sheaves and sheave boxes, blocks, 'U' bolts, sheet catching batten, blanking off caps, tape or other materials for sealing against the rubber seal when pole is retracted and items as permitted or prescribed by other applicable *rules*.

### F.6 STANDING RIGGING

#### F.6.1 MATERIALS

- (a) The standing **rigging** shall be of stainless steel cable.
- (b) The backstay material is optional.

#### F.6.2 FITTINGS

- (a) The following are permitted:
  - Turnbuckles/bottlescrews, tangs, swages, swage eyes, shackles, shroud lock plates.

#### F.6.3 DIMENSIONS – SEE H.2

### F.7 RUNNING RIGGING

#### F.7.1 MATERIALS

- (a) Materials are optional for the main and spinnaker halyards and for the jib halyard with the fixed forestay system.
- (b) The jib halyard for the original system shall be 7x19 stainless steel wire.
- (c) The material and a constant/fixed diameter for sheets and control lines is optional unless specified.

#### F.7.2 CONSTRUCTION

- (a) MANDATORY – SEE H.2
- (b) OPTIONAL – SEE H.2

#### F.7.3 FITTINGS

- (a) MANDATORY
  - (1) Boom Vang

#### F.7.4 DIMENSIONS – SEE H.2

## Section G – Sails

### G.1 PARTS

#### G.1.1 MANDATORY

- (a) Mainsail

(b) Headsail

G.1.2 OPTIONAL

(a) Spinnaker

**G.2 GENERAL**

G.2.1 RULES

(a) **Sails** shall comply with the **class rules** in force at the time of **certification**.

G.2.2 CERTIFICATION

(a) The **official measurer** shall **certify** sails near the **tack** and shall sign and date the **certification mark**.

(b) An MNA may appoint one or more persons at a sailmaker to measure and **certify sails** produced by that manufacturer in accordance with the ISAF In-house Certification Guidelines.

(c) The **certification mark** shall be either the individually numbered class stamp issued to each **official measurer** or the marking system approved by ISAF for In House Certification (IHC) which may require a signature and date.

(d) Each **sail** constructed after 1st January 1997 shall have permanently fixed, (with stitching), near to its **tack**, an official ICA label. No **sail** shall be accepted for its **fundamental measurement** without a sail label. The **measurer** shall sign across the label and sail to ensure that it cannot be transferred to another sail. Labels shall only be available from the ICA secretary (or treasurer) and the cost shall be fixed by the ICA in general meeting.

G.2.3 SAILMAKER

(a) No licence is required.

**G.3 MAINSAIL**

G.3.1 IDENTIFICATION

(a) The class insignia shall conform to the dimensions and requirements as detailed in the diagram contained in Section H.

(b) The word Melges shall be coloured mid to dark blue and the figures 24 shall be coloured teal green.

(c) The class insignia shall be positioned on both sides of the mainsail, between the top two battens with the starboards side being higher.

(d) The national letters and sail numbers shall comply with the RRS.

(e) The national letters and sail numbers shall be positioned on both sides of the mainsail, between the second and third battens.

G.3.2 MATERIALS

(a) The **ply** fibres shall consist of polyester, aramids or HMPE.

(b) **Stiffening** shall consist of:

(1) Cornerboards: plastic or aluminium



(2) Battens: wood, GRP, FRP.

(c) **Sail reinforcement** shall consist of polyester, aramids, HMPE or GRP.

*N.B. Aramid is marketed under trade names such as Kevlar and Twaron and HMPE under trade names such as Spectra and Dyneema.*

### G.3.3 CONSTRUCTION

(a) The construction shall be: **soft sail, single ply sail.**

(b) The **body of the sail** shall consist of **woven** and/or **laminated ply** throughout.

(c) The sail shall have 4 batten pockets in the leech. The upper two shall be full length and extend from leech to luff. The centreline of the 4 batten pockets shall divide the leech into five equal parts, +/- 100mm.

(d) One reef position may be fitted.

(e) **Windows** are permitted below **half width.**

(c) The following are permitted: Stitching, glues, webbing, woven and PTFE tapes, bolt ropes, corner eyes, corner rings, headboard with fixings, Cunningham eye or pulley, Velcro or other fastenings, reefing points, **batten pocket patches**, batten pocket elastic, batten pocket end caps, batten retaining devices, mast and boom slides, leech line with cleat, **windows**, tell tales, sail shape indicator stripes and items as permitted or prescribed by other applicable *rules*.

(g) For mainsails manufactured after the 1st December 2007, the weight of the complete sail shall comply with the weight listed in class rule G.3.4.

a) The sail shall be weighed with fixed fittings but excluding battens and tensioners.

b) The mainsail shall not include any special devices, which are designed to, or might perform the task of corrector weights.

c) Fittings shall be the normal size fittings for a sail of this size and available from standard suppliers.

d) If fittings or construction are designed in any way to circumvent this rule, measurement shall be refused.

### G.3.4 DIMENSIONS

*Where no limit(s) for a particular dimension is given then the item is not controlled and need not be measured*

	minimum	maximum
<b>Leech length</b>	-	9590 mm
<b>Foot Median</b>	-	9200 mm
<b>Half width</b>	-	2700 mm
<b>Three-quarter width</b>	-	1680 mm
<b>Top width</b>	-	175 mm
Reef point above <b>tack</b> and <b>clew</b> points	-	1000 mm
Weight of complete <b>sail</b>	6.0kg	-
<b>Window area</b>	-	1.0 m <sup>2</sup>
<b>Batten pocket length:</b>		
Lower two pockets:		

	minimum	maximum
<b>inside</b>	-	1780 mm

## G.4 HEADSAIL

### G.4.1 MATERIALS

- (a) The **ply** fibres shall consist of polyester, aramids or HMPE.
- (b) **Stiffening** shall consist of:
  - (1) Cornerboards: plastic or aluminium
  - (2) Battens: optional material
- (c) **Sail reinforcement** shall consist of polyester, aramids, HMPE or GRP.

### G.4.2 CONSTRUCTION

- (a) The construction shall be: **soft sail, single ply sail**.
- (b) The **body of the sail** shall consist of the same **woven** and/or **laminated ply** throughout.
- (c) The headsail may have 3 **battens** in the **leech**. The battens shall have one end placed on the leech. The battens shall not prevent the **sail** from furling completely.
- (d) The **leech** shall not extend beyond a straight line from the aft **head point** to the **clew point**.
- (e) **Windows** are permitted below **half width**.
- (f) The jib luff wire if fitted shall be 7x19 or 7x7 or 1x19 and may be coated or non-coated wire.
- (g) The following are permitted: Stitching, glues, webbing, tapes, **luff** wire, corner eyes, corner rings, Velcro or press studs, battens, batten pockets, batten pocket elastic, **batten pocket patches**, batten pocket end caps, Cunningham eye or block with cleat, leech line with cleat, foot line with cleat, **windows**, two blocks for sheets, zip for sleeve **luff**, tell tales, sail shape indicator stripes and items as permitted or prescribed by other applicable *rules*.
- (h) For headsails manufactured after the 1st January 2006, the weight of the complete sail shall comply with the weight listed in class rule G.4.3.
  - a) The sail shall be weighed complete with fixed fittings and jib sheet blocks but excluding battens and jib luff wire.
  - b) The headsail shall not include any special devices, which are designed to, or might perform the task of corrector weights.
  - c) Fittings shall be the normal size fittings for a sail of this size and available from standard suppliers.
  - d) If fittings or construction are designed in any way to circumvent this rule, measurement shall be refused.
- (i) The jib may be fitted with a zip luff designed to enclose the forestay, jib halyard and any purchase system used. The zip shall not be used as a device to alter the sail shape

### G.4.3 DIMENSIONS

Where no limit(s) for a particular dimension is given then the item is not controlled and need not be measured

	minimum	maximum
<b>Luff length</b>	8460 mm	8560 mm
<b>Leech Length</b>	7775 mm	7903 mm
<b>Foot Length</b>	2926 mm	3026 mm
<b>Top width</b>	-	50 mm
<b>Window area</b>	-	0.75 m <sup>2</sup>
Batten Length		1500 mm
Batten Width	10 mm	35 mm
<b>Clew point</b> to intersection of <b>leech</b> and centreline of <b>batten pocket</b>	750 mm	6000 mm
Forward most point of batten from <b>leech</b>		800 mm
<b>Luff</b> wire diameter	4.7 mm	5.1 mm
<b>Luff</b> wire. Length between bearing surfaces	8250 mm	8700 mm
Weight of complete sail	4 kg	

## G.5 SPINNAKER

### G.5.1 MATERIALS

- (a) The **ply** fibres shall consist of non polyester.
- (b) **Sail reinforcement** shall consist of:
  - Primary reinforcement** – material optional
  - Secondary reinforcement** – non polyester

### G.5.2 CONSTRUCTION

- (a) The construction shall be: **soft sail, single ply sail.**
- (b) The **body of the sail** shall consist of **woven ply** throughout.
- (c) **Windows** are permitted below **half width.**
- (d) National letters and sail numbers are optional.
- (e) The following are permitted: Stitching, glues, webbing, woven tapes, corner eyes, corner rings, **windows**, leech line and cleat, luff line and cleat, foot line and cleat, sail shape indicator strips, tell tales and items as permitted or prescribed by other applicable *rules*.
- (f) The weight in g/m<sup>2</sup> of the **body of the sail** shall be indelibly marked near the **head point** by the sailmaker together with the date and his signature or stamp.

### G.5.3 DIMENSIONS

Where no limit(s) for a particular dimension is given then the item is not controlled and need not be measured

	minimum	maximum
<b>Luff Length</b>	11285 mm	11585 mm
<b>Leech length</b>	10000 mm	11078 mm

	minimum	maximum
<b>Foot Length</b>	6000 mm	6300 mm
<b>Foot Median</b>	-	12000 mm
<b>Half width</b>	mm	5860 mm
<b>Three-quarter width</b>	mm	3700mm
Mass of <b>ply</b> of the <b>body of the sail</b>	40 g/m <sup>2</sup>	-
<b>Window area</b>	-	0.75 m <sup>2</sup>

# PART III – APPENDICES

---

The rules in Part III are **closed class rules**. Measurement shall be carried out in accordance with the ERS except where varied in this Part.

## Section H

### H.1

#### Mast datum point

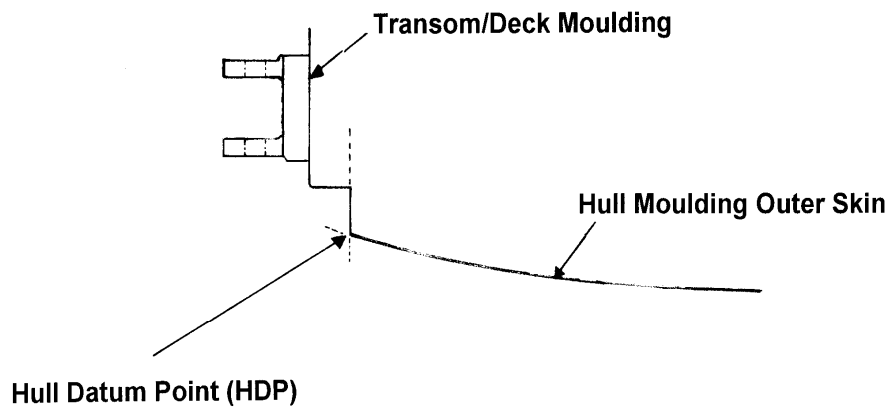
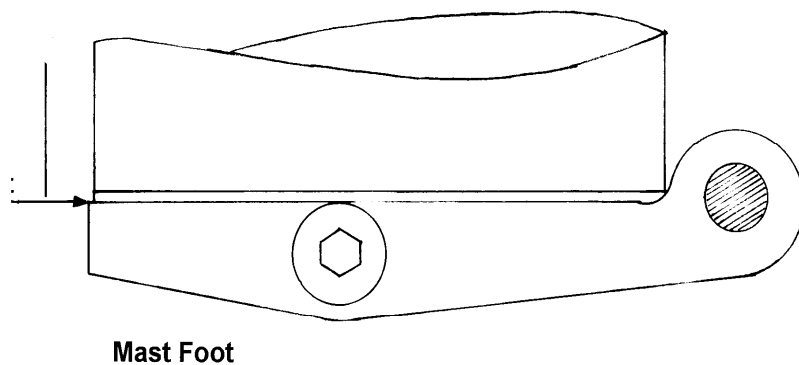

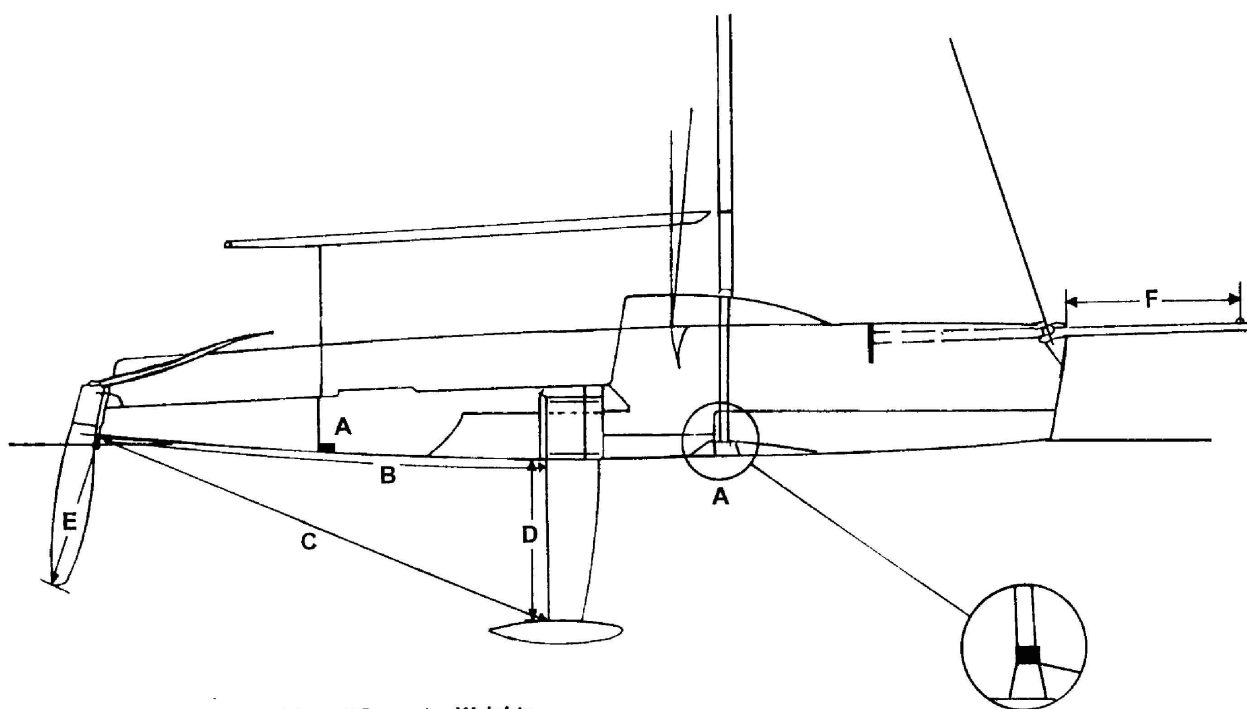
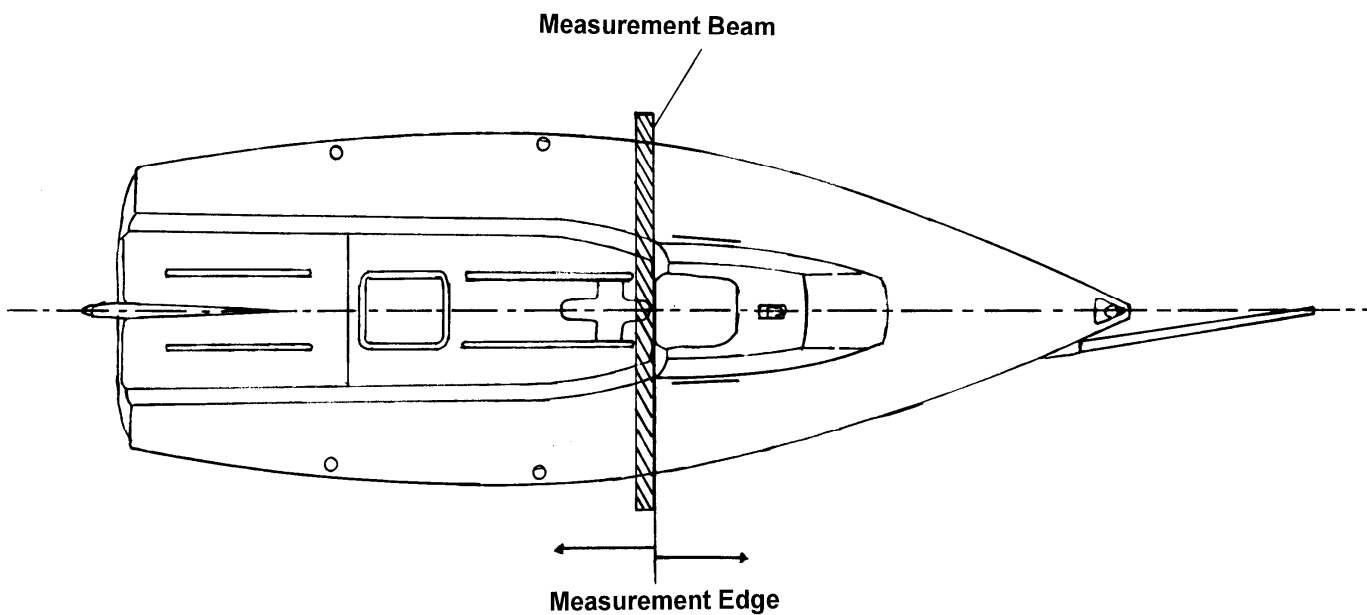

- Key: A = Position of Corrector Weights  
 B = 3482 +3494mm (Class Rule E 3.3.1)  
 C = 3784 +3823mm (Class Rule E 3.3.2)  
 D = 1195 +1215mm (Class Rule E 3.3.3)  
 E = 1220mm max. (Class Rule E 4.3.2)  
 F = 1400mm max. (Class Rule C 6.3.2)

Equal weights secured on either side of mast compression post

Illustration regarding dimension C corrected 5<sup>th</sup> February 1998

Note: On all measurements (excluding angles) relating to the class insignia there is a tolerance of +/- 5mm.

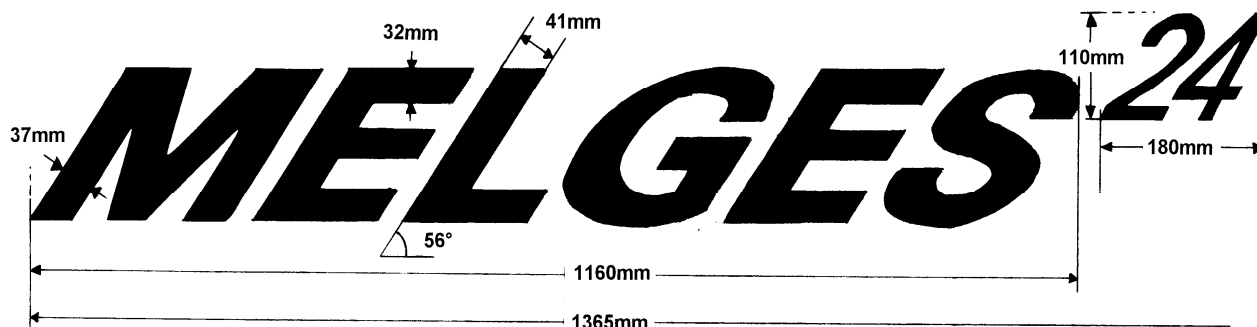

## H.2

Fittings and their positions shall not be modified unless specifically allowed. The manufacturer or brand of blocks, cleats and winches is optional. Block dimensions given below are sheave diameter.

<u>STANDARD FITTING SPECIFICATION</u>	<u>DIMENSIONS</u>		<u>PERMITTED MODIFICATIONS OR DIMENSION SPECIFICATION</u>
	<u>MINIMUM</u>	<u>MAXIMUM</u>	
Bow towing eye.			Factory fitted
Furler drum and forestay attachment			Factory supplied
Shroud plates	360mm	390mm	Longitudinal distance forward of MB as defined in D.2.4(b) to centre of shroud plates
	1725mm	1750mm	Transverse distance between centres of shroud plate at leading face of shroud plate hole centreline. Equal across hull centreline
Mast step	2405mm	2415mm	Horizontal distance from aft face of furler drum recess to forward edge of mast step measured in a straight line
Deck bushes either side of mast step. Jib halyard to port, main halyard to starboard	5 mm ID	12 mm ID	
Fwd hiking line attachment	2470mm	2500mm	Longitudinal distance from MB to fixed forward end of hiking line on deck. The fitting may be substituted for any other of equivalent strength
Two Factory supplied stanchions either side with hiking line.	450mm	475mm	Underside of hole in stanchion above deck
Stern pull pits with gate line			Factory supplied
1 jib sheet track per side	Length	Length	The centreline of the tracks shall lie

	478mm	486mm	alongside the cabin sides on the level deck on the inboard edge of the non slip moulding. Extra holes may be drilled in the track
	510mm	530mm	Longitudinal distance forward of MB as defined in D.2.4(b) to forward end of tracks
	978mm	1000mm	Measured by jig across the centreline of the hull. total distance between centrelines of track forward
	1012mm	1032mm	Measured by jig across the centreline of the hull, total distance between centrelines of track aft
Jib sheet car			Pin or screw position adjustment optional
Jib sheet car block	Dia 30mm	Dia 46mm	
Spinnaker tack line cleat to starboard			May be changed to a stopper. A second cleat may be added on the cockpit/deck
Jib sheet deck ratchet blocks 1 per side	Dia 54mm	Dia 78mm	Position optional
Jib sheet cleats 1 per side			Position optional 1 extra cleat per side may be added
Spinnaker sheet deck ratchet blocks 1 per side	Dia 54mm	Dia 78mm	Position optional
Spinnaker sheet cleats 1 per side			Position optional 1 extra cleat per side may be added
Aft spinnaker turning block deck plates	2650mm	2670mm	Position of turning block deck plates, centre of fitting aft of MB
	15mm	25mm	Position of aft spinnaker turning block deck plates distance from outboard edge of deck moulding
Spinnaker sheet turning block 1 per side	Dia 48mm	Dia 78mm	May be free running or ratchet
Hiking line block on spinnaker turning block deck plate	Dia optional		The block may be substituted for a shackle or the line may be lead through the spinnaker turning block deck plate.
One mainsheet track	2260mm	2370mm	Mainsheet track aft of MB
One mainsheet traveller car			
Main sheet double block on car	Dia 48mm	Dia 58mm	
Mainsheet ratchet block on deck mount with cleat	Dia 54mm	Dia 78mm	The mainsheet swivel cleat may be fitted either forward or aft of the mainsheet track. Alternatively the mainsheet swivel cleat may be removed and the cleat mounted on the lower block.
Double block either side for traveller control line	Dia optional		A block may be added above the traveller cleat, or the traveller may be rigged in such a way as to be able to use a windward sheeting system of optional design, except that the mainsheet shall still be attached to the traveller car in the standard way.
1 or 2 cleats on brackets on each side tank for traveller control line			The traveller cleats may be placed within a box measuring 1900mm and 2150mm aft of the Measurement Beam and between the lower edge of the deck non skid and a line 180mm below this edge on the cockpit moulding.



1 block on deck eye on each side tank to lead traveller control line to cleat	Dia optional		Location optional
3 cheek blocks on cockpit floor and 1 on each side tank for backstay system plus floating block	Dia optional		Location optional
1 cleat on each side tank for backstay			The backstay cleats may be placed within a box measuring 1900mm and 2150mm aft of the Measurement Beam and between the lower edge of the deck non skid and a line 180mm below this edge on the cockpit moulding.
<b><u>ON COCKPIT BULKHEAD</u></b>			
To port, fairlead with cleat behind for furler line			
To starboard, fairlead with cleat behind for bowsprit launch line			
To starboard, fairlead for bowsprit retraction line			The use of the line is optional. The fittings are optional
<b><u>CABIN</u></b>			
Compression post			Factory supplied
Highfield lever and jib halyard attachment on port side with wire tail.			This may be substituted for an optional purchase system for use with a fixed forestay.
Cleat and cheek block on starboard side for main halyard.			Extra cleats or stopper may be added. An additional maximum 4:1 with cleat purchase may be added to assist with halyard tension.
Bowsprit launch blocks on forward mounting knee	29mm	40mm	
<b><u>TRANSOM</u></b>			
Rudder fittings			See rule E.4.4 (a) 1
Backstay attachment fittings			
Mounting lugs for outboard bracket	8mm		
<u>Optional</u> drain bung		25mm internal diameter	If fitted this must be a water tight fitting.
<b><u>PURCHASE SYSTEMS</u></b>			
Mainsheet	5:1		Shall not be modified
Jib sheets	2:1		Shall not be modified
Spinnaker sheets	1:1		Shall not be modified
Main Cunningham	3:1 – 6:1		
Boom Vang	12:1		Shall not be modified
Main outhaul	6:1		Shall not be modified
Traveller Control	3:1		Shall not be modified
Bowsprit Launch system	3:1		Shall not be modified
Backstay	8:1		Shall not be modified
Reefing systems	2:1		Shall not be modified

<b>MAST</b>			
Main Halyard Sheave	45mm	55mm	
Spinnaker Halyard Sheave	36mm	40mm	See F.3.4
Forestay T'Ball Socket	5mm		See F.3.4
Main Shroud T'ball Socket	5mm		See F.3.4
Lower Shroud T'ball Socket	5mm		
Jib Halyard Sheave	72 mm	78 mm	See F.3.4 Factory supplied
Spreader socket			See F.3.4 Factory supplied
Gooseneck fitting			Factory supplied
Spinnaker Halyard Cleat and bracket			A second cleat may be added
Spinnaker Halyard stowage cleat or cleats			
Boom Vang fitting			Factory supplied
Mast foot			Factory supplied
<b>BOOM</b>			
Outhaul sheave	36mm	40mm	
Reefing line fitting			
Two mainsheet block attachments			Factory supplied
Two mainsheet blocks	Dia 48mm	Dia 58mm	The two single blocks may be combined into a double block
Boom Vang fitting			Factory supplied
Gooseneck socket			Factory supplied
Spinnaker halyard stowage clip			Optional
<b>BOWSPRIT</b>			
Below deck: Two through sheaves at aft end. Eye strap for optional retraction line.	26mm		Cheek block under deck for optional retraction line
Location stop ring on aft end of bowsprit below deck			See C.9.5.(b)
Gaiter on hull and end plug in bowsprit			Factory supplied
Eye bolt at outer end of bowsprit			See C.9.5.(b)
End block on eye bolt	Dia optional		
<b>STANDING RIGGING</b>			
Forestay	Dia 4.7mm	Dia 5.1mm	T'ball at upper end with swage linked to turnbuckle or similar at lower end. Fixed to top of furler drum
Jib luff wire if used	Dia 4.7mm	Dia 5.1mm	
Main Shrouds	Dia 4.7mm	Dia 5.1mm	T'ball at upper end with swage linked to turnbuckle or similar at lower end. Fixed through spreaders
Lower Shrouds	Dia 4.7mm	Dia 5.1mm	T'ball at upper end with swage linked to

			turnbuckle or similar at lower end.
Backstay	Stainless steel 3.0mm		Spliced loop at backstay crane. Block or ferrule at lower end. Block and ferrule size optional
	Breaking strain if not s/s wire 950kg		
<b><u>RUNNING RIGGING</u></b>			
Jib Clew blocks	Dia 26mm	Dia 30mm	
Main Halyard	Dia 4.7mm		May be tapered
Headsail Halyard s/s wire	Dia 4.7mm	Dia 5.1mm	Shall be 7x19 cable
Headsail Halyard for use with fixed forestay	Dia 2.5mm		
Spinnaker Halyard			May be tapered
Spinnaker Sheets			May be tapered
Headsail Sheets			Must be lead through clew blocks and jib track car blocks. May be tapered
Main sheet			May be tapered
Traveller control system			
Backstay control system			
Mainsail Cunningham			
Mainsail outhaul in boom			
Headsail furler line			
Headsail Cunningham on sail			
Bowsprit launch line			
Bowsprit retraction line			OPTIONAL – line only
Reefing line			OPTIONAL
Vang purchase line			
Hiking lines 7x10 s/s coated wire	Dia 3.1mm		
Hiking Line HMPE	Dia 4.5mm		

### H.3

Crews shall be weighed during the registration period prior to racing. During the event, Crews will be selected at random to be reweighed. Such reweighting shall be done on the same scale and at the same place and within one (1) hour of the end of the protest time limit of the last race of the day. Should a boat be found to exceed the maximum weight, she will be penalized by adding one point for each race of the day to her final total score - after discards - of the regatta for every kilogram over the limit. A boat found over the weight limit shall not continue racing until she complies with the class rule. Re-weighing under this situation shall be at the discretion of the Race Committee.

Effective:	22 March 2013
Previous issues:	19th March 2012
	1st July 2011
	5 <sup>th</sup> January 2010
	1 <sup>st</sup> January 2009
	4th Jan 2008
	23 <sup>rd</sup> May 2007
	1 <sup>st</sup> March 2006

© ISAF 2013